

NAFCO International 8' to 39' Round Tapered Fluted Steel 12 Flat Flute "12F" Series

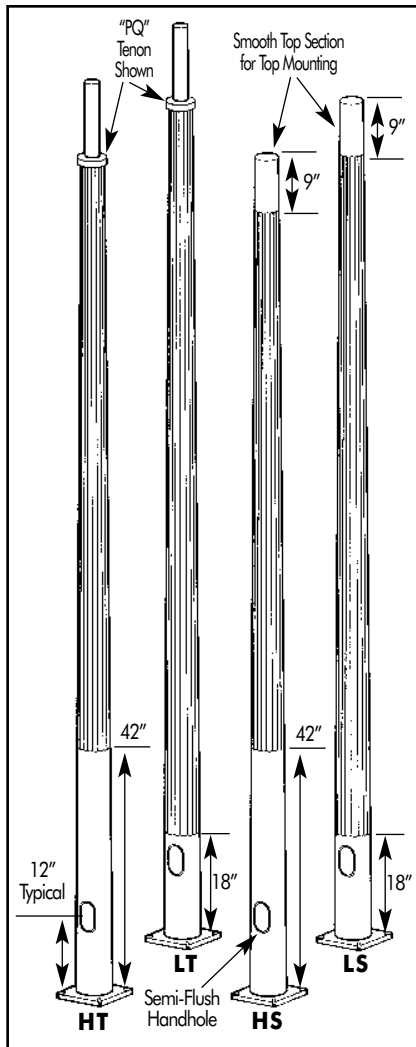

Flute Layout Options

SPECIFICATIONS

Pole: Fluted poles are formed from tubes conforming to the ASTM A595 process with a constant linear taper of 0.14"/ft. The wall thickness is available in 11 ga. (0.1196") or 7 ga. (0.1793"). The tube's seam weld is formed by the Electric Resistance Weld (ERW), and is smooth with no visual appearance.



Fluting Process: The poles are cold rolled over a precision hardened steel mandrel to form the fluted shape indicated. The fluted shaft has uniform Doric flutes. The flutes are formed with rollers in full contact with the material from the top of the crest, through the valley of the flute, to the top of the next crest. The termination of the flutes is no greater than 1-1/2" radii transition into the round section of the pole.

Semi-flush Handhole: The reinforcing handhole rim consists of a nominal 2-1/2" x 5" oval shaped pipe material. The handhole is provided with a steel attachment bar, steel cover and one round head machine screw. The handhole is welded with the rim extending 1/4" out of the pole shaft and shaped to match the diameter of the pole.

Pole Top Tenon: Pole top tenons are fabricated from structural quality hot rolled carbon steel with yield strength of 30,000 psi. A pole top plate of hot rolled commercial quality carbon steel is welded to the top of the pole shaft.

Anchor Bolts and Base Plate: Anchor bolts are fabricated from carbon steel bar conforming to the requirements of ASTM F1554 Grade 55. The upper 12" of the bolts are hot dip galvanized per ASTM A153. Each anchor bolt is supplied with two hex nuts and two flat washers. Base plates conform to ASTM A36 and are integrally welded to the tubes with a socket welded joint.

Pole Top Cap: A removable cap is provided in conjunction with drilled shafts for direct luminaire arm attachment.

Decorative Nut Covers: The optional decorative nut covers are manufactured of a sandcast aluminum alloy 356.2 and are attached to the pole using stainless steel, self tapping hex head screws.

Electrical Ground: A nut holder is provided near the handhole and includes a 1/2" - 13UNC hex head bolt and nut.

Finish: The finish for the pole is polyester powder applied coating in accordance with NAFCO Specifications.

CATALOG LOGIC

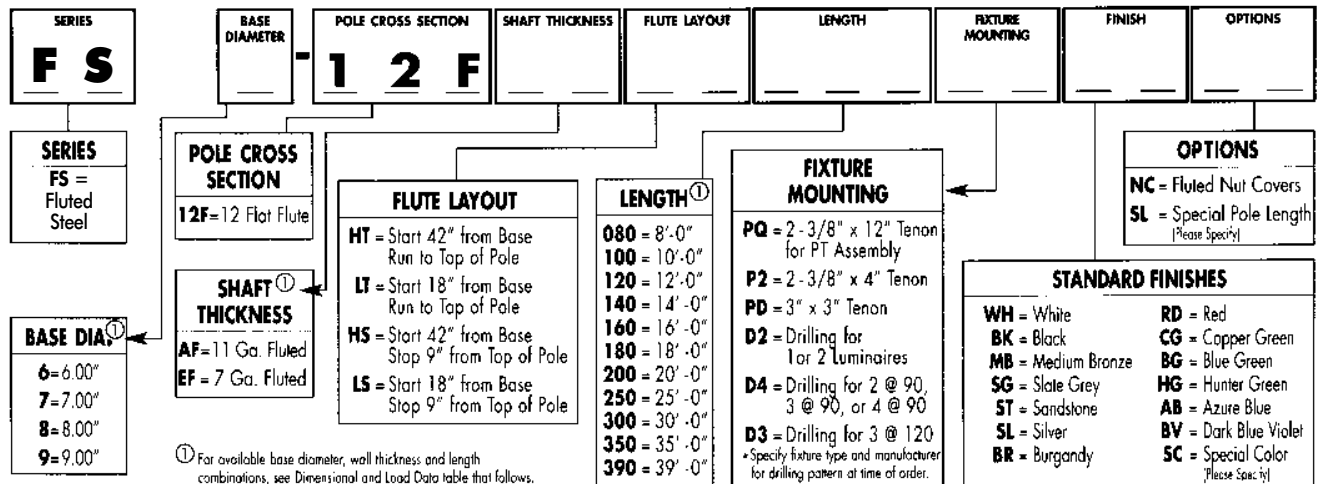

Serving our customers and the industry with quality products since 1973.

8' to 39' Round Tapered Fluted Steel 12 Flat Flute "12F" Series

ANCHOR BASE AND BOLT DIMENSIONS

Semi-Flush Steel Reinforced Handhole

The handhole is a unique semi-flush reinforced design. Rim is curved to match pole diameter in the smooth section of the pole and extends only 1/4" from the pole surface.



Cast Nut Cover

When ordering poles without base assembly, cast nut cover option can be specified to provide an attractive pole base finish.

Anchor Base Detail

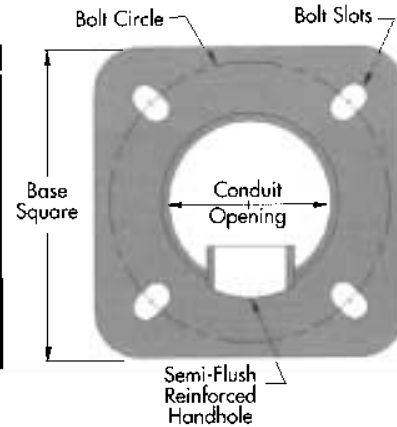

POLE DIA. (IN)	BASE DIMENSIONS (SEE DETAIL)				ANCHOR BOLTS	
	BOLT CIRCLE	BASE SQUARE	CONDUIT OPENING	BASE THK.	BOLT SIZE	BOLT PROJECT.
6.00"	9.50" ± 0.50"	10.50"	5.50"	0.75"	0.75" x 17.00" x 3.00"	3.50" ± 0.25"
7.00"	10.00" ± 0.50"	11.00"	6.50"	1.00"	1.00" x 36.00" x 4.00"	4.25" ± 0.25"
8.00"	11.00" ± 0.50"	11.75"	7.50"	1.00"	1.00" x 36.00" x 4.00"	4.25" ± 0.25"
9.00" ¹	12.50" ± 0.50"	12.00"	8.50"	1.25"	1.25" x 42.00" x 6.00"	5.00" ± 0.25"
9.00" ²	12.50" ± 0.50"	13.50"	8.50"	1.25"	1.25" x 42.00" x 6.00"	5.00" ± 0.25"

¹ Pole Diameter includes base cover.

² Pole Diameter includes nut covers.

STANDARD DIMENSIONAL AND LOAD DATA

POLE HEIGHT (FT)	CATALOG NUMBER ^(A)	SHAFT				80 MPH ^(B)		90 MPH ^(B)		100 MPH ^(B)	
		BASE O.D. (IN)	TOP O.D. (IN)	WALL THK. (GA)	STRUCT. WEIGHT (LBS)	MAX EPA (SQ FT)	MAX WEIGHT (LBS)	MAX EPA (SQ FT)	MAX WEIGHT (LBS)	MAX EPA (SQ FT)	MAX WEIGHT (LBS)
8	FS-6-12F-AF-(FL)-080-(M)-(F)-(O)	6.00	4.88	11	82	28	260	22	260	18	260
10	FS-6-12F-AF-(FL)-100-(M)-(F)-(O)	6.00	4.60	11	94	18	260	14	260	11	260
12	FS-6-12F-AF-(FL)-120-(M)-(F)-(O)	6.00	4.32	11	106	15	260	12	260	9	260
14	FS-6-12F-AF-(FL)-140-(M)-(F)-(O)	6.00	4.04	11	116	13	260	10	260	7	260
16	FS-6-12F-AF-(FL)-160-(M)-(F)-(O)	6.00	3.76	11	126	11	260	8	260	6	260
16	FS-7-12F-AF-(FL)-160-(M)-(F)-(O)	7.00	4.76	11	151	24	260	18	260	14	260
18	FS-7-12F-AF-(FL)-180-(M)-(F)-(O)	7.00	4.48	11	163	21	260	15	260	12	260
20	FS-7-12F-AF-(FL)-200-(M)-(F)-(O)	7.00	4.20	11	174	18	260	13	260	10	260
20	FS-8-12F-AF-(FL)-200-(M)-(F)-(O)	8.00	5.20	11	203	23.5	260	17.5	260	13	260
25	FS-7-12F-AF-(FL)-250-(M)-(F)-(O)	7.00	3.50	11	199	11	260	8	260	5	260
25	FS-8-12F-AF-(FL)-250-(M)-(F)-(O)	8.00	4.50	11	234	15.5	260	10.5	260	7.5	260
30	FS-8-12F-AF-(FL)-300-(M)-(F)-(O)	8.00	3.80	11	261	11	260	7	260	4	260
30	FS-9-12F-AF-(FL)-300-(M)-(F)-(O)	9.00	4.80	11	307	17.5	260	12	260	8	260
30	FS-9-12F-EF-(FL)-300-(M)-(F)-(O)	9.00	4.80	7	436	24.5	260	17.5	260	12.5	260
35	FS-9-12F-AF-(FL)-350-(M)-(F)-(O)	9.00	4.10	11	335	12.5	260	7.5	260	4.5	260
35	FS-9-12F-EF-(FL)-350-(M)-(F)-(O)	9.00	4.10	7	478	19	260	13	260	8.5	260
39	FS-9-12F-AF-(FL)-390-(M)-(F)-(O)	9.00	3.54	11	355	9	260	5	260	2	260
39	FS-9-12F-EF-(FL)-390-(M)-(F)-(O)	9.00	3.54	7	507	15	260	9.5	260	6	260

^(A) Replace (FL) with Fluting Layout Code, (M) with Fixture Mounting Method Code, (F) with Finish Code and (O) with Options Code.

^(B) EPA calculations allow for 1.3 Wind Gust Factor. Variations from standard sizes listed above, available upon inquiry at the factory. Satisfactory performance of lighting standard is dependent upon the pole(s) being properly attached to a supporting foundation of adequate design. NAFCO does not design or offer recommendations for foundations.

Dimensions and Specifications subject to change without notice.